

ALUSPACE

INTERNAL HINGED DOORS

Assembly Instructions

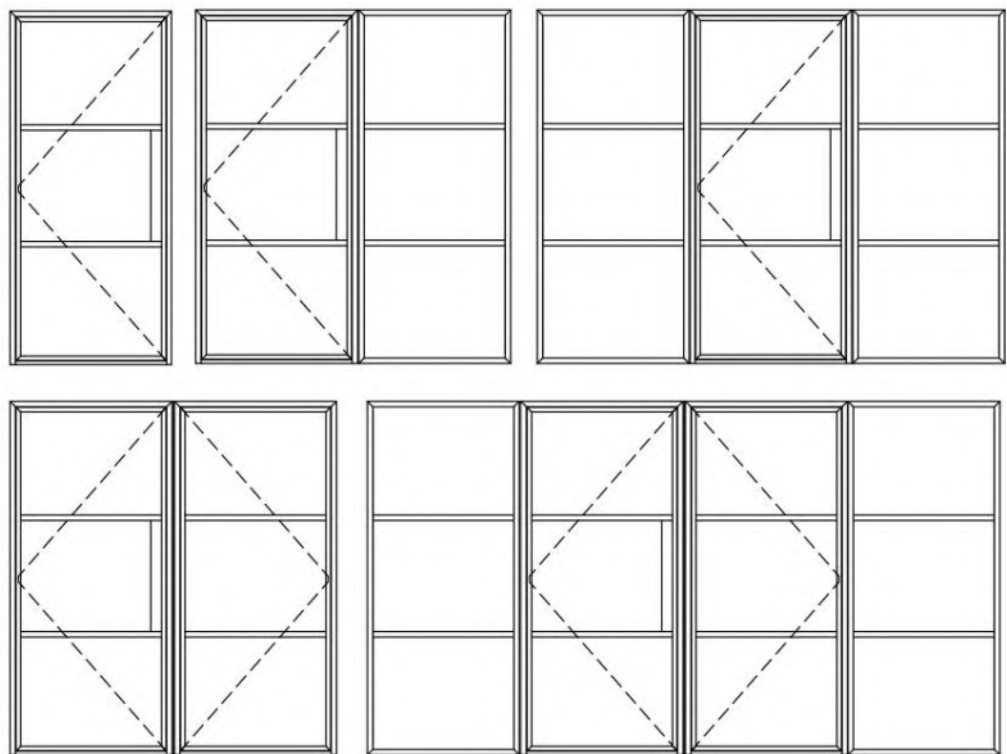

About your Aluspace internal doors

All Vufold Aluspace doors, frames and sidelights powder coating finish, single glazed units and hardware components are guaranteed for a full 10 years against the occurrence of manufacturing faults, all subject to correct installation, regular maintenance, and care in use as detailed below.

Powder Coating finish and maintenance

All our Aluspace door sets are supplied fully powder coated providing a high quality and durable finish, unless otherwise specified.

Our standard colour is Jet black – RAL 9005 Matt finish. If you have selected an alternative custom colour option and require the colour and RAL code, please contact a Vufold team member and they will provide this for you.

To maintain the powder-coated finish, wash regularly with soapy water and then dry off with a soft lint-free cloth.

We cannot accept any claims for damages, including scratches to the powder coating and aluminium reported 72 hours following delivery and / or after installation has commenced.

Installation

Our ready-to-assemble internal Aluspace doors are supplied with all the essential items and virtually everything pre-machined. This design allows for simple on-site assembly by a competent DIYer or experienced trades person(s).

Important: For doors with sidelights only; if you intend on installing or have already installed under floor heating, please ensure that you have the heating pipe or mat location plan, as the sidelights require fixing down into the floor. If the current fixings are not suitable due to their length, please use an alternative fixing (not supplied) to ensure the sidelight is securely fixed down

Importantly; the frame needs to be installed perfectly square and level on all planes into the opening and is designed to be installed on top of the finished floor level. If installing onto a sub floor, which will then have flooring on top of it, you will need to install the frame allowing of the thickness of the flooring or floor covering.

Single glazed units

Tempered glass means it has been toughened to be up to five times stronger than normal glass. It is unusual to break such strong glass, but sharp objects hitting the glass at certain points can cause breakage. Tempered glass is also known as safety glass. This means that if it breaks it will shatter into smaller fragments which are less likely to cause injury, unlike non-tempered glass which breaks into large, sharp fragments.

Glass must be regularly maintained and cleaned. This can be done using a mild solution such as washing-up liquid diluted in water. Do not use abrasive cleaning solutions as this may cause scratching.

Visual distortions caused by reflections in toughened glass are a natural phenomenon and not a fault.

Toughened, glass is acceptable if bubbles or blisters, fine scratched no more than 2.5cm long and / or minute particles or neither obtrusive nor bunched. The glass used is a processed glass therefore certain blemishes are unavoidable.

For carrying out a glass inspection, stand at least 3 metres away from the glazing, view at a 90-degree angle and look directly through the glass. The glass must be viewed in natural daylight but not with the sun directly on it. Any moisture must be removed from the surface of the glass before inspecting.

Hardware components

The hardware in your internal Aluspace door set can deteriorate from everyday use. That's why regular maintenance of your door hardware is important.

We require that the below minimum maintenance is carried out as often as necessary to prevent deterioration. As a guideline, we recommend that this maintenance is done every six months otherwise your guarantee will not be valid.

About your Aluspace internal doors (Cont)

Hinges, and bolts

Using a microfibre cloth, wipe down the visible surfaces with warm soapy water and then rinse off by wiping with a clean, damp cloth. Applying a thin film of light machine oil or silicone spray, wiping with a dry cloth to remove any excess, will help to maintain the original lustre of the metal finish. Be careful not to get these liquids on the aluminium as this can cause staining.

The bolts should be maintained using silicone spray by directing the nozzle into the applicable areas. Always hold a cloth directly under the nozzle to prevent any over spray or liquid running onto the timber.

Door latch and handles

The magnetic latch will remain in the body of the lock until the door is closed and will automatically engage once it is aligned with the receiver plate. Pulling the handle lever down will then retract the magnetic latch.

All moving parts should be lubricated using a silicone spray.

The handles should be regularly cleaned with a soft damp microfibre cloth to remove any dust or grime taking care not to scratch the surface.

All our pre-glazed Aluspace internal door sets have been pre-assembled in our factory. They are installed into a steel framed testing rig where they are glazed and then fully operated, including checking the doors open and close smoothly. The door sets are then part dismantled, packaged up ready for dispatch and onsite assembly.

It is important that if you feel any resistance when operating the handle, you do not continue to operate the doors as this may eventually cause damages and will invalidate your guarantee. Please contact a member of our customer service team so we can assist you further.

Introduction to Assembly

QUICK GUIDE

Every Aluspace door is pre-assembled in our factory to ensure they are operating perfectly before we deliver it. Depending on the size of the door set, we then dismantle the doors and remove some hardware, before carefully packing it for transportation to your home. Single doors will remain hinged to the outer frame and packed together.

Your Aluspace internal doors are supplied with the frame built-up ready for assembly on site.

Our standard doors are all pre-glazed and the glazing is "toe and heeled" in our factory, to balance the glazing in each door, then in the full set. Sidelights are supplied unglazed to allow for easy access to the fixing points for fixing into the opening and to the frame.

When you receive your Aluspace door set, to install it, fix the outer frame into the stud / brickwork opening. Attach the hardware to the doors and install the doors into the frame. Because our Aluspace doors have already been assembled and operated in our factory, as long as the frame is installed securely into the opening, completely level and square in every plane, and the hardware is correctly attached, then the installed Aluspace doors should operate perfectly, without the need for further adjustment.

**Full and detailed installation instructions are contained
within this Instruction booklet**

Contents

IMPORTANT: Please check the contents of the packages to ensure that all parts are present and in good condition before booking your installation

Door, frame and sidelight components	Single Door Qty	French Door Qty	Single Sidelight Qty	Double Sidelight Qty
Frame (head, left & right jambs)	1	1	-	-
Door and glass (pre-glazed)	1	2	-	-
Frame cover strips	1	1	-	-
Sidelight and glass (unglazed)	-	-	1/(3 pcs glass)	2/(6 pcs glass)
Sidelight coupler (pre-fitted)	-	-	1	2
Sidelight glazing bead (temp-fitted)	-	-	12	24
Wedge gasket roll	-	-	1	1

Hardware components	Fitted Qty	Loose Qty
Door handle pair	1	-
Door latch	1	-
Latch plate	1	-
Finger flush bolts (French doors only)	2	-
Finger flush bolt keeps (French doors only)	1	-
Glazing packers (sidelights only)	fitted	-
Hinges (single door)	3	-
Hinges (French doors)	6	-
Hinge clamp screws	5 (per hinge)	-
Hinge final fix screws	1 (per hinge)	-

Fixing kit contents	Single Door Qty	French Door Qty	Single Sidelight Qty	Double Sidelight Qty
Direct frame fixings	12	15	14	19
6.5mm SDS drill bit	1	1	-	-
6.5mm masonry drill bit	1	1	-	-
TX30 1/4 hex insert bit	1	1	-	-
Self drilling screws (25mm)	-	-	6	12
PH2 1/4 hex insert bit	-	-	1	1

Preparing the site

When preparing the site, please prepare the brickwork / stud wall opening to be 10mm more in height and in width than the outside assembled frame size.

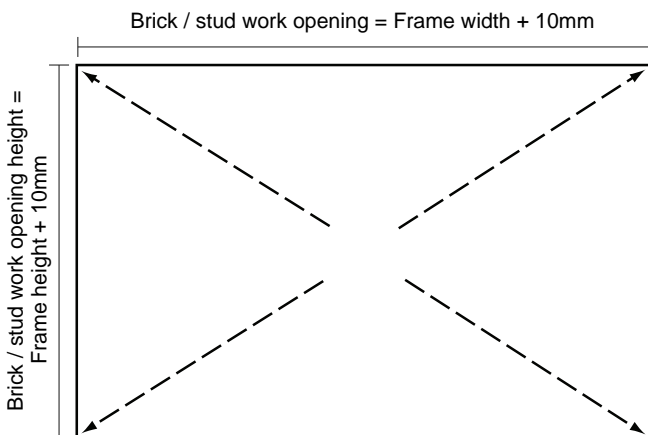

It is essential that all the internal surfaces of the brick / stud work are level before installation. Please ensure that all dimensions are correct for installation before proceeding, as the door set must be installed square and level into the opening.

The brick / stud wall opening is classed as a finished opening size so it is important you have allowed for any additional plaster works or architraves.

Finishing around the frame is a personal preference and should be decided between yourself and the installer.

VERY IMPORTANT.

The frame and doors are designed to be installed **ON TOP OF THE FLOORING** or floor covering. If installing onto a sub floor, which will then have flooring on top of it, you will need to install the frame allowing for the thickness of the flooring / covering.

Opening options

Our Aluspace internal doors are not reversible and therefore can only be installed in the opening direction specified on your order, eg left or right.

Opening direction

The direction the doors open towards will be determined by which way round you install the outer frame into the opening. The same frame can be installed to have the doors opening towards or away from you by rotating the assembled outer frame 180 degrees.

Example shows jamb position & opening direction on French Doors

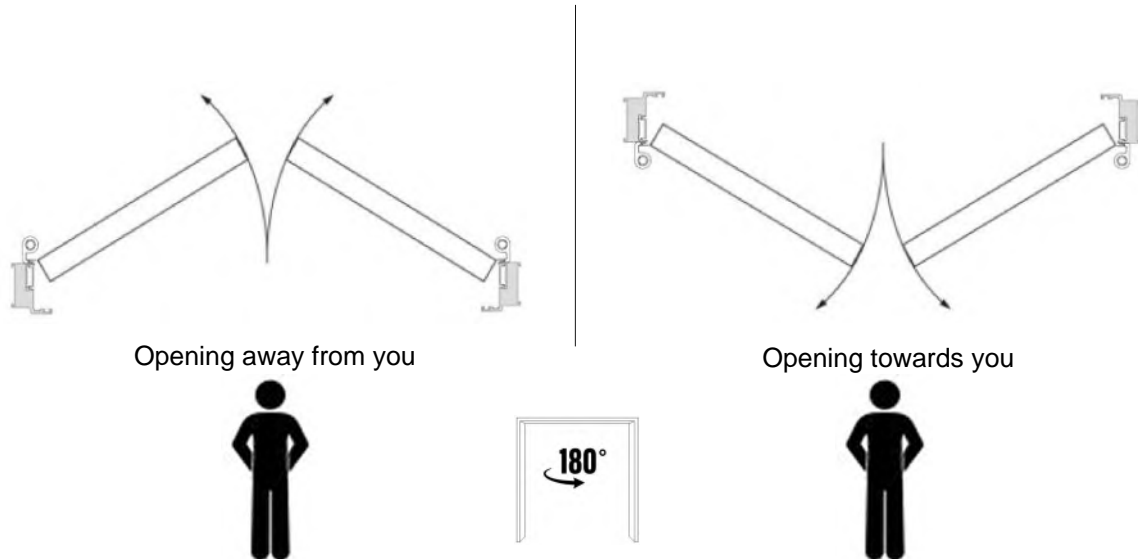

Door configuration

Which side you have the Access door is determined at the point of ordering and cannot be reversed.

Single door

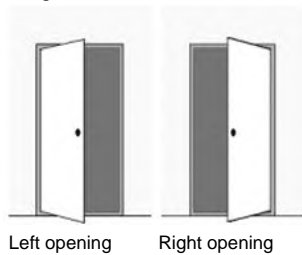

Single door with single sidelight

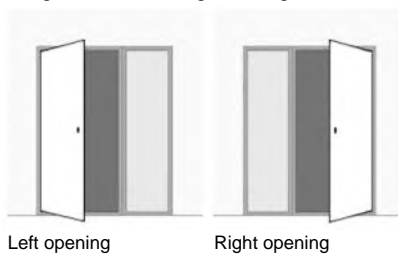

Single door with double sidelight

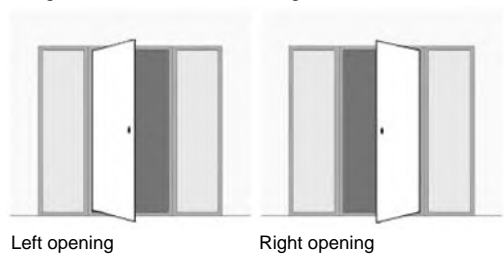

French door

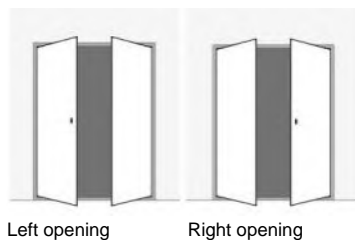

French door with double sidelights

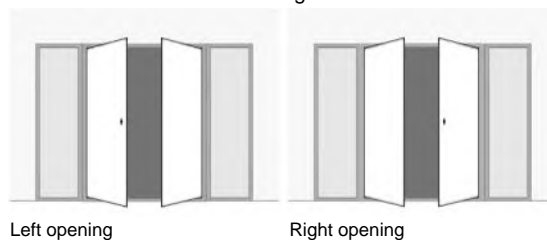

Single doors without sidelights

Single doors without sidelights will come with the door already hinged to the built-up outer frame.

Care should be taken when handling the single doors with the attached door in the open position before the outer frame is securely fixed into the opening, to ensure the frame is not damaged or twisted.

A timber section will be affixed to the bottom of the frame to ensure stability during transportation, which should be removed before installation.

Lift the frame and door into the opening and temporarily secure in place using air wedges and/or packers, ensuring the frame is perfectly square and level on all planes. Once the frame is secured in place you can open the door and final fix the frame into the opening. Please follow the below instructions 'Installing the assembled door frame', you can skip the 'Hanging the doors' section on Page 8.

Ensure a second person is always on hand to help steady the door and frame during these installations.

Sidelights

Your sidelight will be supplied unglazed to allow access to the fixing points. Fix the sidelight to the frame by screwing the self drilling screws (Qty 6 single sidelight & Qty 12 double sidelight) through the pre-machined holes in the frame and then into the coupler that has already been pre-fitted to the sidelight, using the PH2 bit provided. Ensure the sidelight is securely fixed to the frame and is straight and level.

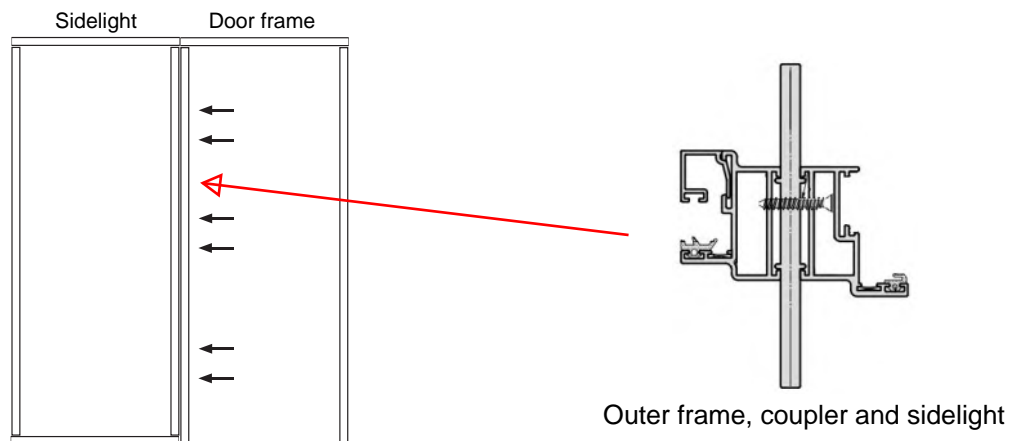

The assembled frame and sidelight can now be installed into the opening.

Installing the assembled door frame

The outer frame supplied is rebated, with a combined frame and door stop in one piece. The frame can be rotated 180 degrees prior to installation to alter if the doors will open towards you or away from you, see page 5 for diagrams.

For transportation purposes, a timber section has been screwed to the bottom of the frame. Remove the timber before fitting the frame into the opening.



Installing the assembled door frame (cont)

Proceed to install the assembled frame.
It is critical that the frame is fitted square and level.

Ensure the frame is installed straight and square.
 Use shims / packers between the frame and the opening.

The height (H) must be the same across the whole width of the opening.

The diagonals must be the same.
It is very important the frame jambs are level. Place a spirit level on the face and sides of each jamb and check before proceeding.

Secure the assembled frame into the brickwork / stud wall opening using the direct frame fixings supplied (unless the construction of your building requires more appropriate fixings to suit the individual dwelling).

Frame fixing points will vary depending on the construction of the opening. If needed screw into a good hardwood timber baton secured into the cavity.

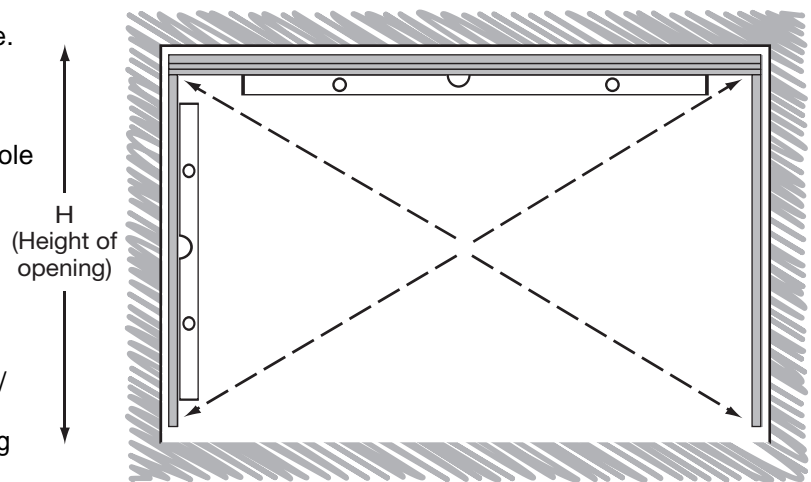

Installing the assembled door frame (cont)

Important: When drilling and fixing the frame into the opening, take extra care not to bend the aluminium frame.

Before drilling for the sidelight fixing, please ensure that there are no under floor heating pipes or mats in the intended location. An alternative fixing (not supplied) may be required. Please ensure the sidelight is securely fixed down.

Use the direct frame fixings as follows;

- Use the 6.5mm HSS drill supplied to drill the holes in the frame jambs.
- Use the 6.5mm SDS masonry drill supplied to drill into the brickwork.
- Use a Torx T30 bit to screw in the direct frame fixings.

Very important: Carefully check the frame is tightly fixed together and is square. Diagonals of the frame must be equal. Do not proceed with installation if the frame is not square.

Please see below diagrams for recommended fixing positions → Frame fixing points

Single door

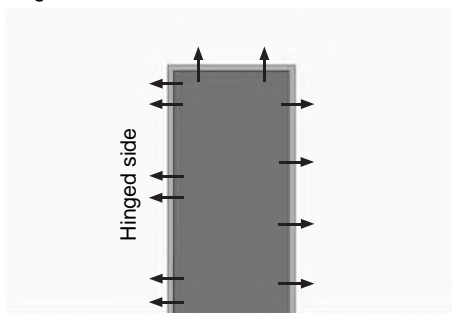

Single door and single sidelight

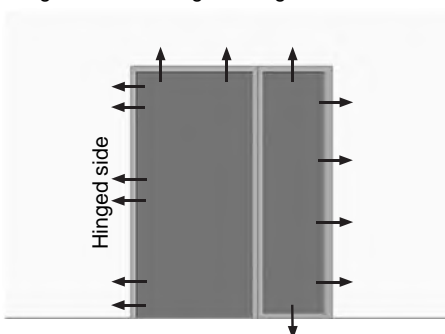

Single door and double sidelights

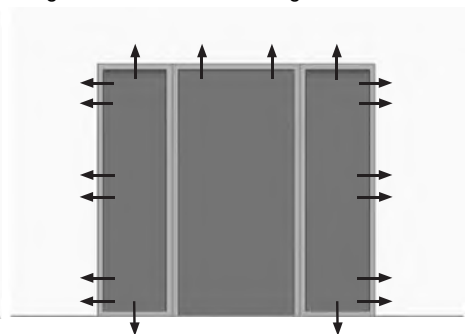

Installing the assembled door frame (cont)

French door

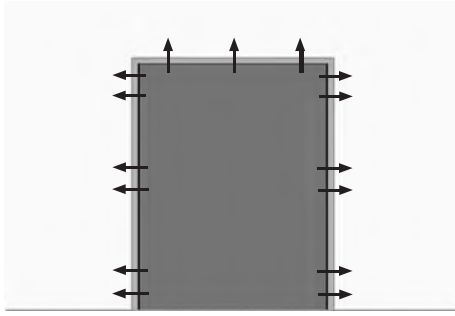

French door and double sidelights

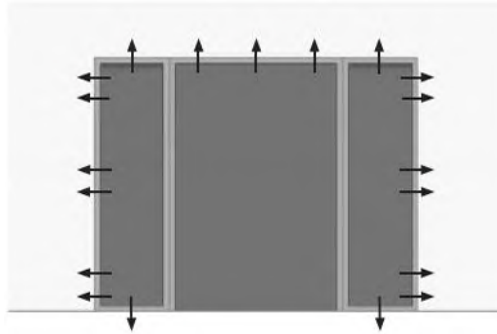

Fixing point through sidelights

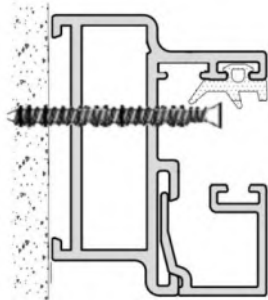

Fixing point through door frame

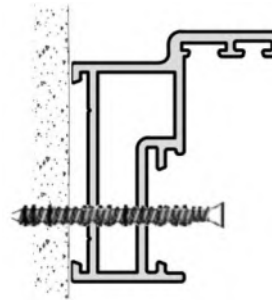

Hanging the doors

The hinges and screws will already be attached to the doors. The door to frame hinge clamping screws and final fixing screws are temporarily fitted to the frame jamb hinge plates.

Hold the hinge back plate in position to stop it from sliding downwards and remove the screws.

Using air bags or under door wedge supports, offer the door up to the frame hinge plates.

Locate each hinge in the outer frame and clamp into position using Qty 2 clamp machine screws per hinge, in the top and bottom holes.

Once you have checked the door is aligned to the frame correctly fix through the centre holes using the self-tapping screws provided, Qty 1 per hinge.

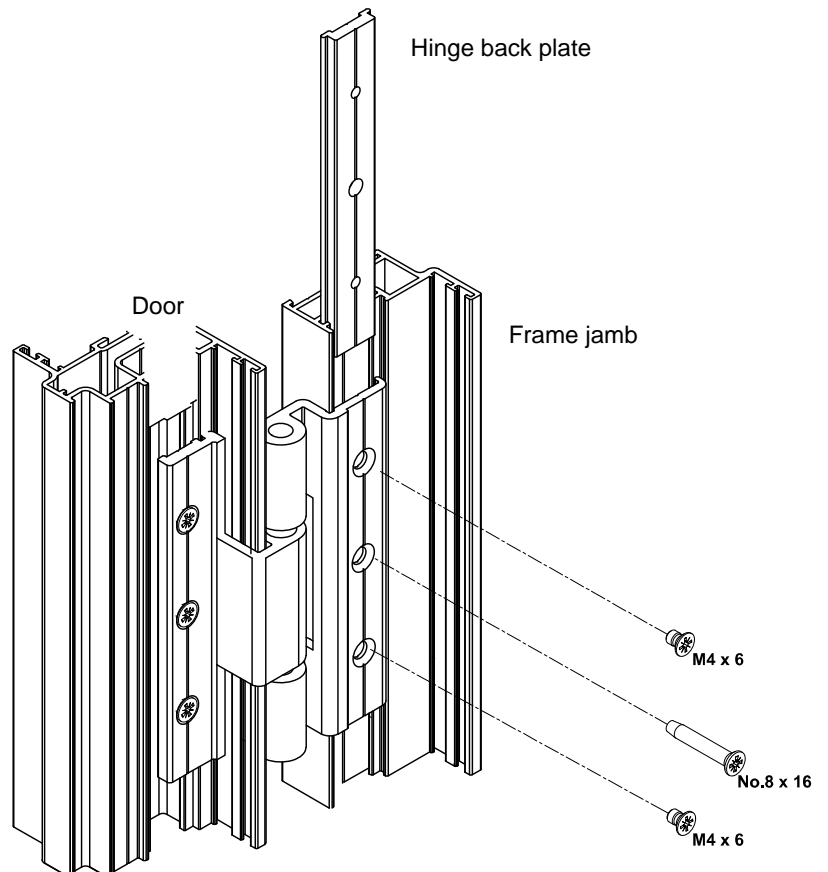

Glazing the sidelights

Once the frame and sidelights have been fully installed into the opening perfectly square and level on all planes, install the side light glass, beading and wedge gasket.

Install the glass into the sidelight, ensuring the glass is pushed up against the pre-fitted retaining gasket and on the glazing packs. Push the glazing bead into place, locating into the sidelight profile and then install the wedge gasket.

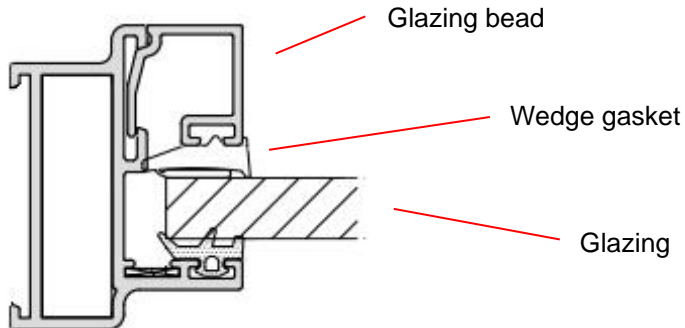

Flush bolts and keeps



The finger / flush bolts have been pre fitted to the edge of slave door.

Once you are 100% happy the doors are correctly fitted, aligned and operating smoothly, it is recommended that you drill a 8 – 10mm diameter hole in the floor for the bottom finger / flush bolt to locate into.

Using a bottom flush bolt provides greater rigidity when the doors are operated and closed, and it is our recommendation this is used. If however, it is preferred NOT to drill a hole into the flooring, please note well that the doors will be less rigid and it will also cause the doors to sit slightly out of line.

Close the slave door and engage the top and bottom finger / flush bolts, now close the access door. Making sure the doors are full aligned, mark the floor as to where the bottom bolt would strike the flooring, open the access door and disengage the bolts. Before drilling the hole, please make sure the doors are not misaligned. Once you are happy with the location, drill a 8 – 10mm hole into the flooring for the bottom finger / flush bolt to engage into.

Cover trims

Finally cut and fit the plastic cover trim to the outer frame jambs and head, covering the frame fixings.

